

# Commercial Stainless

ITEM # \_\_\_\_\_

QTY. \_\_\_\_\_

MODEL # CWSR

## ROLLED FRONT WALL SHELF

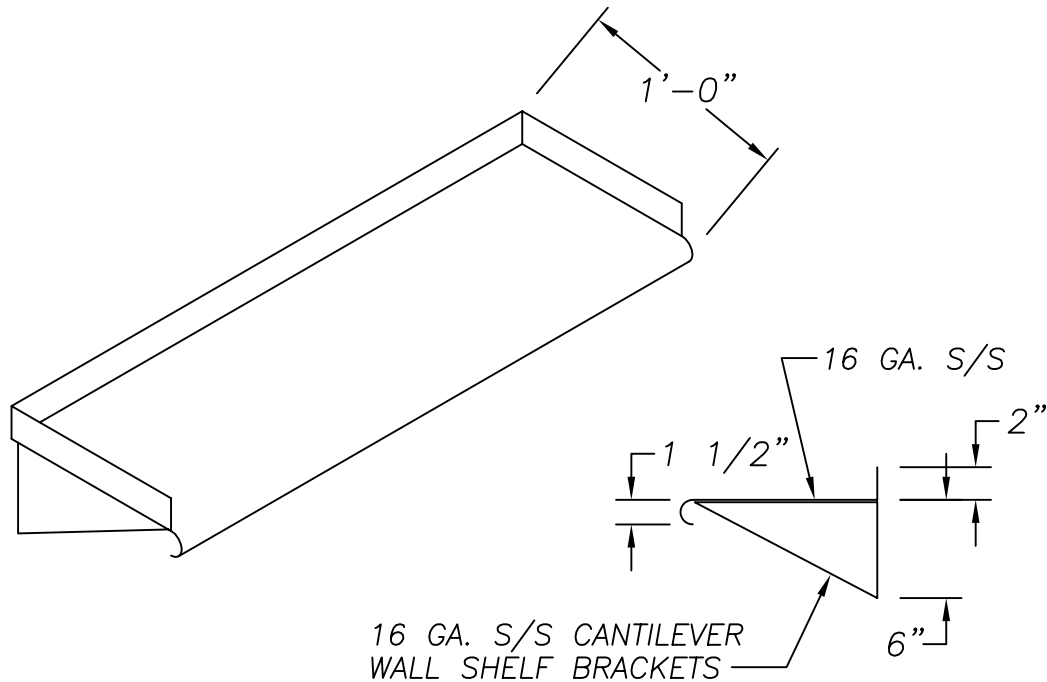

### SPECIFICATIONS

WALL SHELVES TO BE 16 GA. TYPE 304, 18/8 TYPE STAINLESS STEEL, POLISHED TO A # 4 SATIN FINISH. REAR & BOTH ENDS TO BE TURNED UP 2", FRONT EDGE IS TO BE A 1 1/2" DIAMETER ROLLED EDGE. BRACKETS ARE TO BE 16 GA. S/S. SOUND DEADENING ADHESIVE TO BE USED FOR FASTENING SHELF TO BRACKETS.

### OPTIONS

- |                            |                                  |
|----------------------------|----------------------------------|
| 1. 14 GA. S/S              | 2. L-SHAPED                      |
| 3. 18 GA. S/S              | 4. FIELD JOINT                   |
| 5. TURN-DOWN RIGHT END     | 6. SPLASH MOUNTED                |
| 7. TURN-DOWN LEFT END      | 8. FRONT TO BACK DIMENSION _____ |
| 9. STUD-BOLTED TO BRACKETS | 10. LENGTH _____                 |
| 11. 14 GA. S/S BRACKETS    |                                  |

955 PATTERSON DRIVE  
BLOOMSBURG, PA. 17815  
TELEPHONE: (570) 387-8980 FAX: (570) 387-8982



CUSTOM BUILT  
FOODSERVICE  
EQUIPMENT

