

Commercial Stainless

ITEM # _____

QTY. _____

MODEL # CUCB

UTILITY CABINET WITH BACKSPLASH

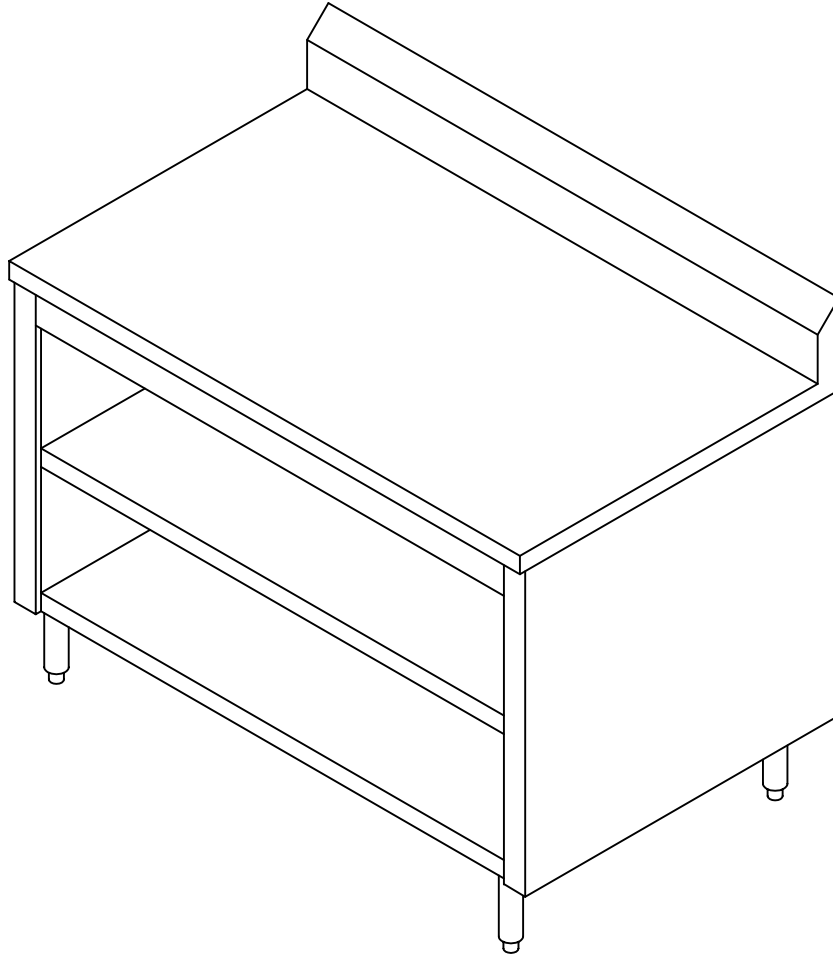

SPECIFICATIONS

UTILITY CABINET TO HAVE 14 GA. TYPE 304, 18/8 STAINLESS STEEL, POLISHED TO A # 4 SATIN FINISH. TOP EDGE TO HAVE 1 1/2" TURN DOWN ON ALL SIDES & 1/2" RETURN ON FRONT EDGE. BOTTOM & INTERMEDIATE SHELVES TO BE 18 GA. S/S WELDED TO 18 GA. S/S SHELF ENDS. BOTH ENDS OF UNIT TO HAVE 18 GA. S/S END PANELS. BACKSPLASH TO BE TURNED UP ON 1/4" RADIUS, 6" VERTICALLY, & BACK 2" ON A 45° ANGLE. LEGS TO BE 1 5/8" O.D. S/S, 6" HIGH WITH ADJUSTABLE S/S BULLET FEET. ALL WELDS TO BE GROUND SMOOTH & POLISHED.

955 PATTERSON DRIVE
BLOOMSBURG, PA. 17815
TELEPHONE: (570) 387-8980 FAX: (570) 387-8982



CUSTOM BUILT
FOODSERVICE
EQUIPMENT 

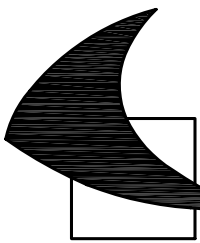

Commercial Stainless

ITEM # _____

QTY. _____

MODEL # CUCB

UTILITY CABINET WITH BACKSPLASH

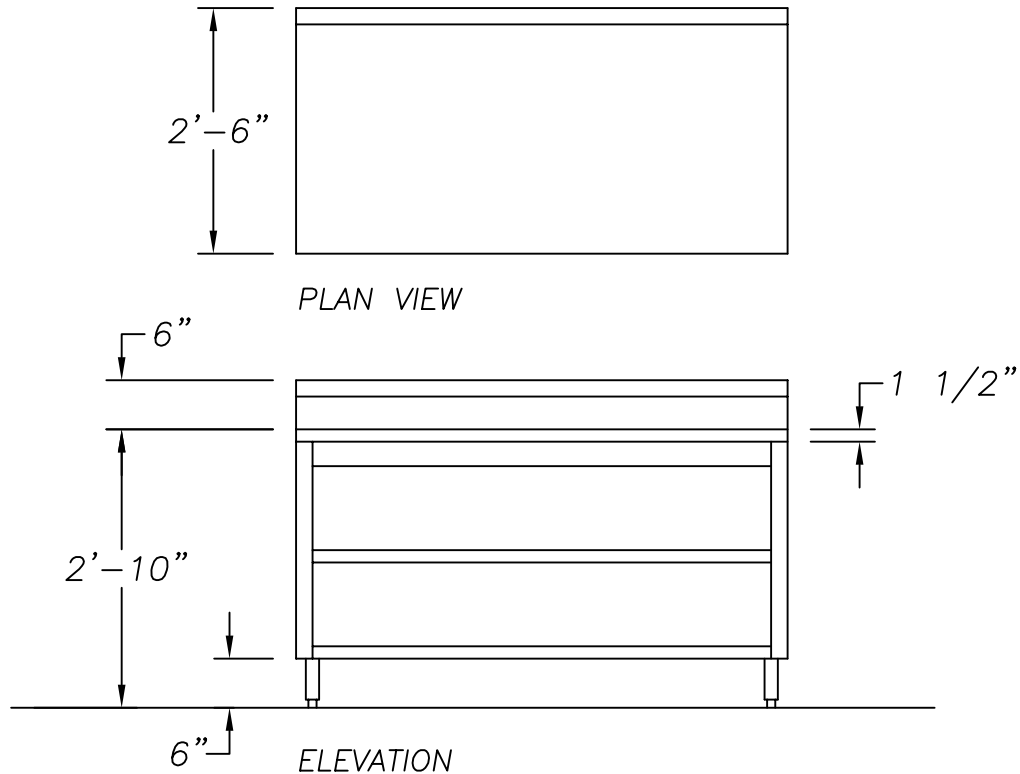

OPTIONS

- | | |
|----------------------------------|-----------------------------------|
| 1. 16 GA. S/S TOP | 2. ROLLED EDGE TOP |
| 3. MARINE EDGE TOP | 4. DELETE INTERMEDIATE SHELF |
| 5. 5" DIA. SWIVEL CASTORS | 6. 1 1/4" SQUARE STEEL FRAME |
| 7. URN TROUGH | 8. 1 1/4" SQUARE S/S FRAME |
| 9. FLANGED FEET | 10. DRAWER |
| 11. SOUND DEADENING | 12. REMOV. S/S KICKPLATE |
| 13. WHITE POLY CUTTING BOARD | 14. REMOV. LAMINATED KICKPLATE |
| 15. S/S TRAY SLIDE | 16. SPLASH ON LEFT END |
| 17. PLASTIC LAMINATED PANELS | 18. SPLASH ON RIGHT END |
| 19. ___" X ___" X ___" DEEP SINK | 20. 3/4" R. TURN-UP ON BACKSPLASH |
| 21. DRAIN | 22. LENGTH _____ |
| 23. 3/4" TURN-UP ON SHELVES | 24. 1" THICK BACKSPLASH |

955 PATTERSON DRIVE
BLOOMSBURG, PA. 17815
TELEPHONE: (570) 387-8980 FAX: (570) 387-8982



CUSTOM BUILT
FOODSERVICE
EQUIPMENT 