

# Commercial Stainless

ITEM # \_\_\_\_\_

QTY. \_\_\_\_\_

MODEL # CSR

## SLANT RACK

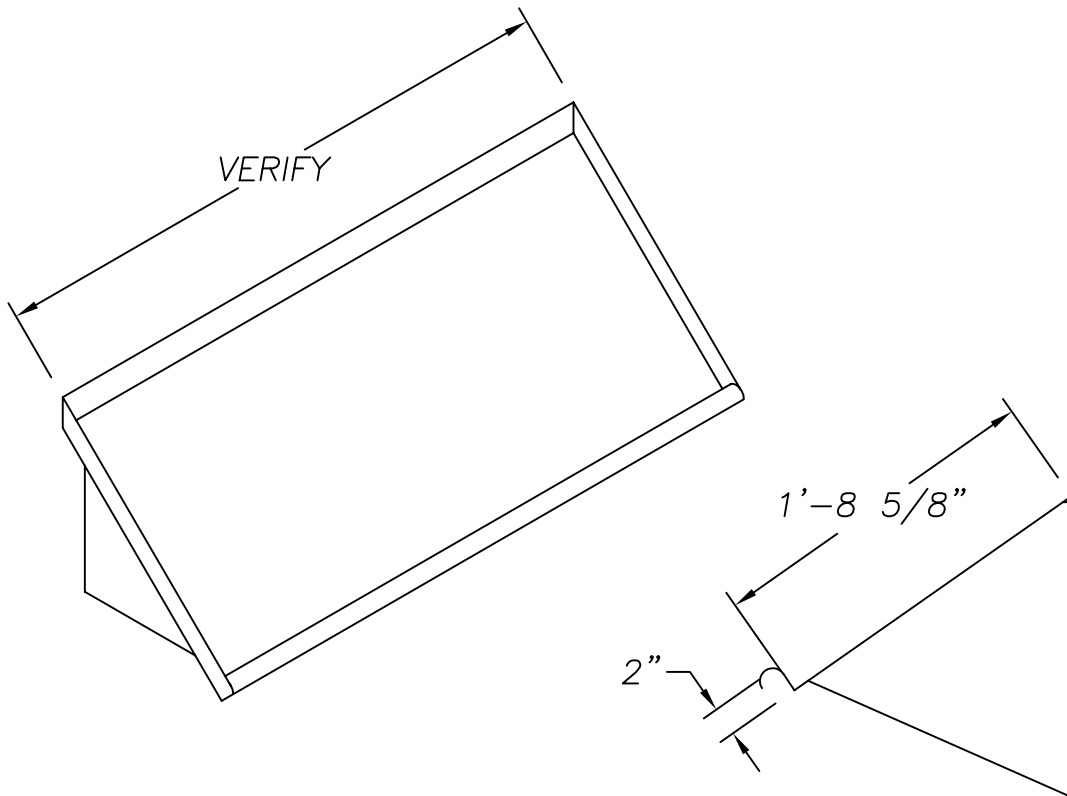

### SPECIFICATIONS

SLANT RACK IS TO BE 16 GA. TYPE 304, 18/8 STAINLESS STEEL, POLISHED TO A # 4 FINISH. SHELF TO ACCOMMODATE A 20" X 20" DISH RACK. SHELF TO BE STUD BOLTED TO 14 GA. S/S CANTILEVER BRACKETS. SLANT RACK TO BE PROVIDED WITH A 3/8" DRAINAGE HOLE.

### OPTIONS

1. DRAINAGE HOLE LEFT END
2. DRAINAGE HOLE RIGHT END
3. 18 GA. S/S
4. EXTRA BRACKETS
5. SPLASH MOUNTED WITH 1 1/4" O.D. S/S UPRIGHTS

955 PATTERSON DRIVE  
BLOOMSBURG, PA. 17815  
TELEPHONE: (570) 387-8980 FAX: (570) 387-8982



CUSTOM BUILT  
FOODSERVICE  
EQUIPMENT 