



# Commercial Stainless

ITEM # \_\_\_\_\_

QTY. \_\_\_\_\_

MODEL # CDSR

## DOUBLE SLANT RACK

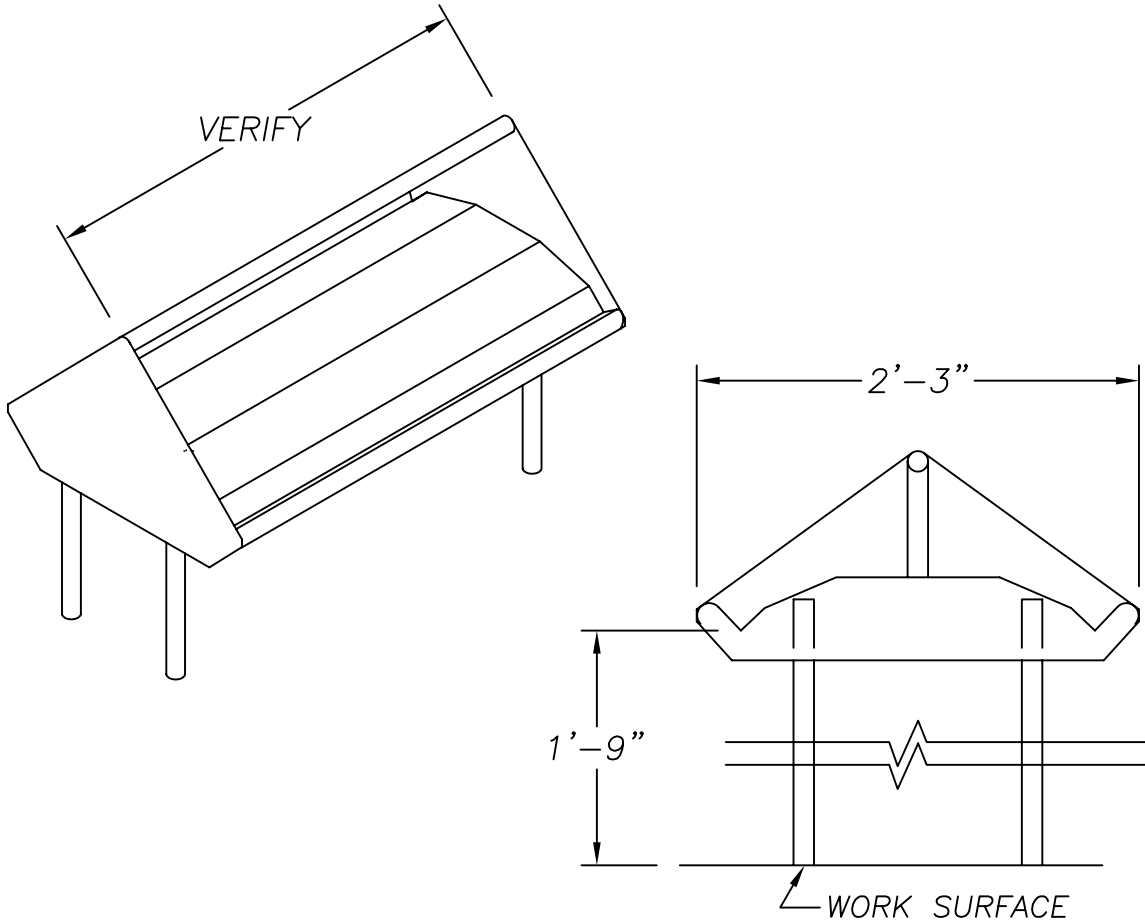

### SPECIFICATIONS

DOUBLE SLANT RACK TO BE 16 GA. TYPE 304, 18/8 STAINLESS STEEL, POLISHED TO A # 4 FINISH. SHELF TO BE WELDED TO 14 GA. S/S ENDS. 1 1/4" O.D. S/S TUBING TO BE WELDED TO TOP OF ENDS TO SUPPORT TOP OF 20" X 20" DISH RACKS. UNIT IS TO BE SUPPORTED BY 1 1/4" O.D. S/S UPRIGHTS WHICH FASTEN TO TOP BY EXPANDING FASTNERS.

### OPTIONS

1. 14 GA. S/S
2. FASTEN TO WALL
3. FASTEN UPRIGHTS TO ROLL
4. EXTEND UPRIGHT THROUGH SPLASH

955 PATTERSON DRIVE  
BLOOMSBURG, PA. 17815  
TELEPHONE: (570) 387-8980 FAX: (570) 387-8982



CUSTOM BUILT  
FOODSERVICE  
EQUIPMENT 