



# Commercial Stainless

ITEM # \_\_\_\_\_

QTY. \_\_\_\_\_

MODEL # CWTRB1/4

WORKTABLE WITH ROLLED EDGE TOP  
AND BACKSPLASH (1/4" RADIUS)

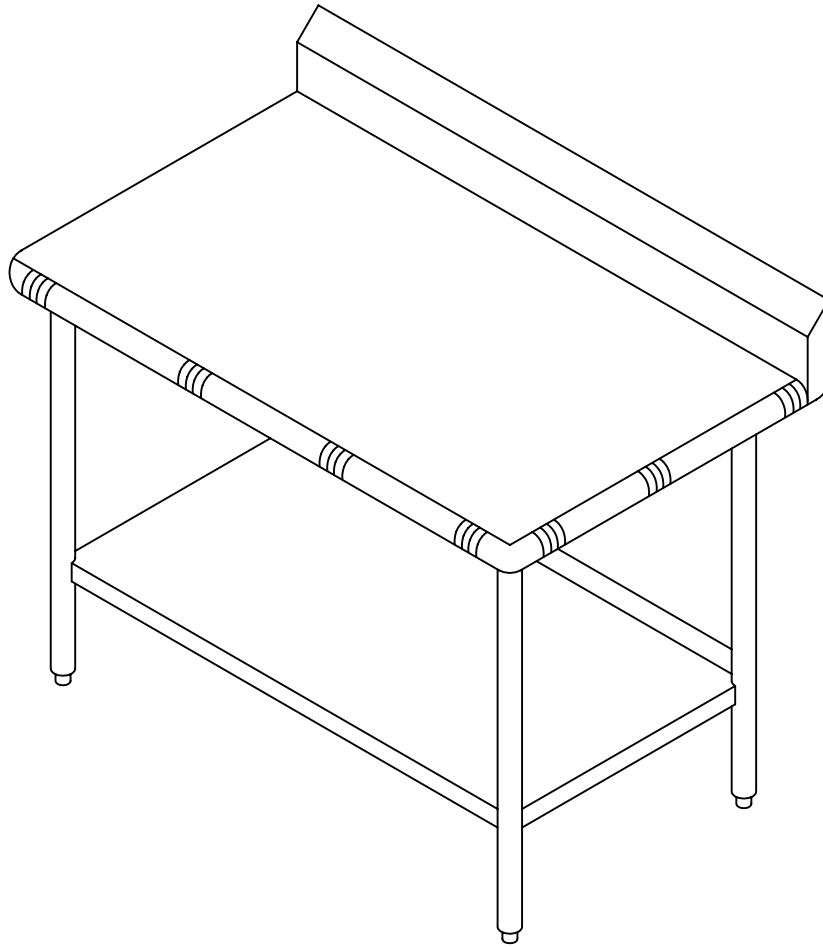

## SPECIFICATIONS

WORKTABLE TOP TO BE 14 GA. TYPE 304, 18/8 STAINLESS STEEL, POLISHED TO A # 4 SATIN FINISH. TOP TO HAVE EDGES ROLLED DOWN ON A 1 1/2" DIAMETER. TABLE TO HAVE S/S CHANNEL STUD BOLTED TO TOP, WITH S/S LEG GUSSETS WELDED TO CHANNEL. LEGS TO BE 1 5/8" O.D. S/S TUBING WITH ADJUSTABLE S/S BULLET FEET. 16 GA. S/S UNDERSHELF TO BE NOTCHED & WELDED TO LEGS. UNDERSHELF TO BE TURNED UP 2" AT BACKSPLASH LOCATIONS. ALL JOINTS TO BE CONTINUOUSLY WELDED, GROUND SMOOTH, & POLISHED. BACKSPLASH TO BE TURNED UP ON A 1/4" RADIUS, 6" VERTICALLY, & BACK 2" ON A 45° ANGLE.

955 PATTERSON DRIVE  
BLOOMSBURG, PA. 17815  
TELEPHONE: (570) 387-8980 FAX: (570) 387-8982



CUSTOM BUILT  
FOODSERVICE  
EQUIPMENT 

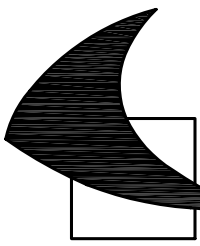

# Commercial Stainless

ITEM # \_\_\_\_\_

QTY. \_\_\_\_\_

MODEL # CWTRB1/4

## WORKTABLE WITH ROLLED EDGE TOP AND BACKSPLASH (1/4" RADIUS)

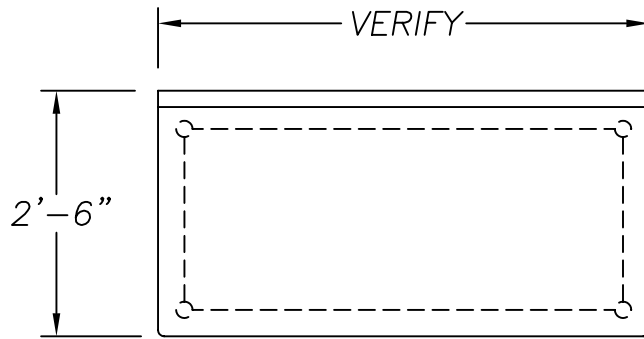

PLAN VIEW

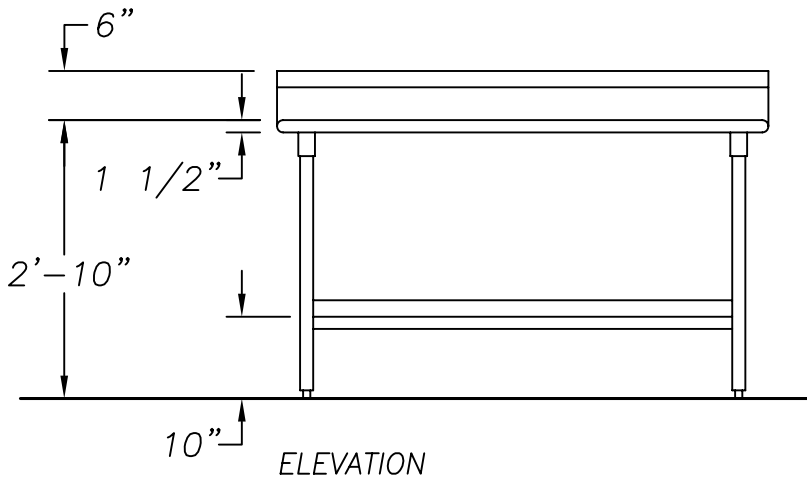

### OPTIONS

- |                                  |                           |
|----------------------------------|---------------------------|
| 1. 16 GA. S/S TOP                | 2. ROLLED MARINE EDGE TOP |
| 3. OPTIONAL UNDERSHELF           | 4. DRAWER                 |
| 5. FLANGED FEET                  | 6. SOUND DEADENING        |
| 7. 1" O.D. S/S CROSSRAIL         | 8. URN TROUGH             |
| 9. 1 1/4" O.D. S/S CROSSRAIL     | 10. LEFT END SPLASH       |
| 11. ___" X ___" X ___" DEEP SINK | 12. RIGHT END SPLASH      |
| 13. OPTIONAL DRAIN               | 14. SPECIAL SPLASH HEIGHT |
| 15. S/S WALL SPACERS             | 16. 1" THICK SPLASH       |

955 PATTERSON DRIVE  
 BLOOMSBURG, PA. 17815  
 TELEPHONE: (570) 387-8980 FAX: (570) 387-8982



CUSTOM BUILT  
 FOODSERVICE  
 EQUIPMENT 